

Model 4288-5 Dual Fixed Rack Mounting Kit

Keithley Instruments
28775 Aurora Road
Cleveland, Ohio 44139
1-800-935-5595
<http://www.tek.com/keithley>

Installation instructions

Introduction

This document contains the parts list and installation information for the Model 4288-5 Dual Fixed Rack Mounting Kit. The kit includes all of the hardware necessary for side-by-side rack mounting for any of the two following 3 1/2-in. high instruments:

| | | | |
|-------|-------|------|-------|
| 2000 | 2302 | 2700 | 6485 |
| 2001 | 2303 | 2701 | 6487 |
| 2002 | 2304A | 6220 | 6514 |
| 2010 | 2306 | 6221 | 6517B |
| 2015 | 2308 | 6430 | |
| 2182A | 2510 | 6482 | |

The rack mounting kit can be installed in a standard 19-in. rack.

Parts list

| Use | Part number | Quantity | Item description |
|--|--------------|----------|---|
| Assembly | 4288-5-301 | 1 | Chassis |
| | BR-21 | 2 | Bracket, rear support |
| | 4288-5-303 | 1 | Front panel |
| | 4288-5-304 | 1 | Front panel, blank |
| | 4288-4-302 | 2 | Clamp (for all 3 1/2 in. products) |
| | 4288-4-304 | 2 | Spacer (for all 3 1/2 in. products other than the Models 2000 and 2010) |
| | 4288-9-301A | 1 | Bracket, rear support, left |
| | 4288-9-302A | 1 | Bracket, rear support, right |
| Fasteners | | | |
| Rear support brackets to chassis | 10-32KEPNUT | 4 | 10-32 Keps® nut |
| | 10-32x3/8PPH | 4 | 10-32 x 3/8 in. Phillips pan head screw |
| Rear support brackets and front panel to rails | FA-148 | 8 | Fastener, captive nut |
| | 10-32x5/8PPH | 8 | 10-32 x 5/8 in. Phillips pan head screw |
| Clamps to chassis | 8-32x3/8PPH | 4 | 8-32 x 3/8 in. Phillips pan head screw |
| Spacer to fastener | FA-240 | 4 | Plastic fastener |



Rack preparation

To prepare the rack:

1. Select a location in the rack. The assembly uses 133.35 mm (5 ¼ in.) of vertical space.
2. Hold up the front panel to the selected location in the rack. The four slotted mounting holes in the front panel show the location of the captive nut fasteners on the four rack rails.
3. Referring to the below figure, install the four fasteners so that the captive nut fasteners are located behind the appropriate holes on the front rack rails.

Figure 1: Fastener installation

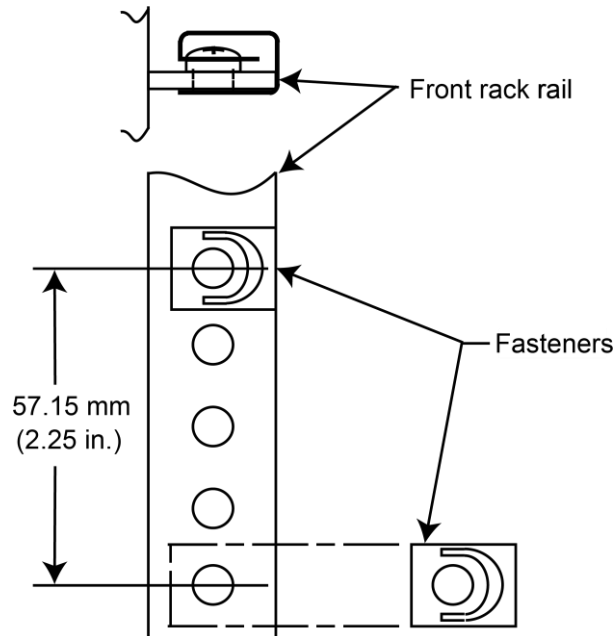

Instrument preparation

To prepare the instrument:

1. Remove the handles from the instruments. There are two styles of handles; the newer style has orientation arrows at each handle end that are molded into the plastic. With the old style handle, rotate it to the uppermost position. With the new style, rotate it under the instrument until the arrows on the handle line up with arrows on the mounting ears. Pull out on the handle ends until the handle is clear of the mounting ears, and then remove the handle.
2. Remove the screw that secures each mounting ear to the case, and remove both mounting ears.

NOTE

Save all removed parts for re-installation if the instrument is removed from the rack in the future.

Mounting kit installation

Refer to the next figure to install the chassis, support brackets, and front panel in the rack and to attach the instruments to the chassis.

NOTE

You can use either the BR-21 or 4288-9-301A and 4288-9-302A brackets to support the rear of the chassis. Before beginning, select the appropriate brackets for the installation based on your rack's rail-to-rail depth. Keep the unused set of brackets for future installations or recycle.

To install the mounting kit:

1. Loosely attach the rear support brackets to the chassis with Keps nuts and 10-32 x 3/8 in. screws.
2. Position the chassis assembly to the front and rear rack to adjust the rear support brackets and note the position for the captive nut fasteners on the rear rack rails.
3. Install the four fasteners so the captive nuts are located behind the appropriate holes on the rear rack rails.
4. Loosely attach the chassis assembly to the front and rear rack rails with 10-32 x 5/8 in. screws. Secure the rear support brackets to the chassis.
5. Loosely attach the front panel to the rack rails.

Figure 2: Mounting kit installation

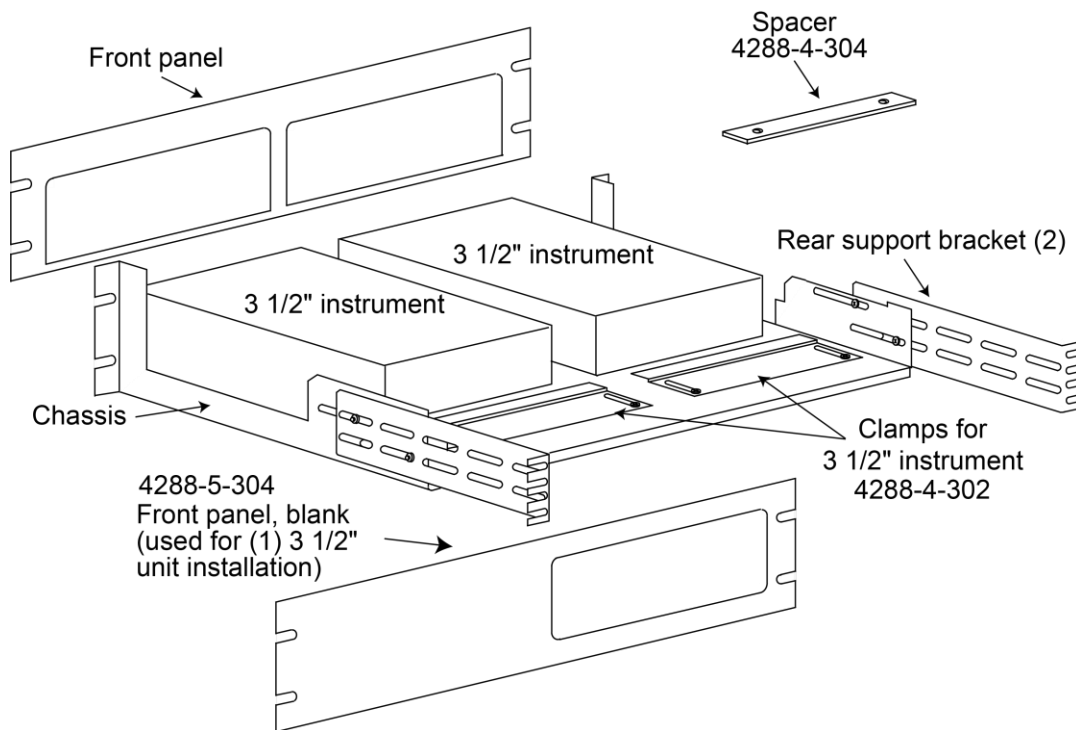

Finalizing installation

To finalize the installation:

1. For all but the Models 2000 and 2010, install the spacer as shown in the next figure.

Figure 3: Spacer installation

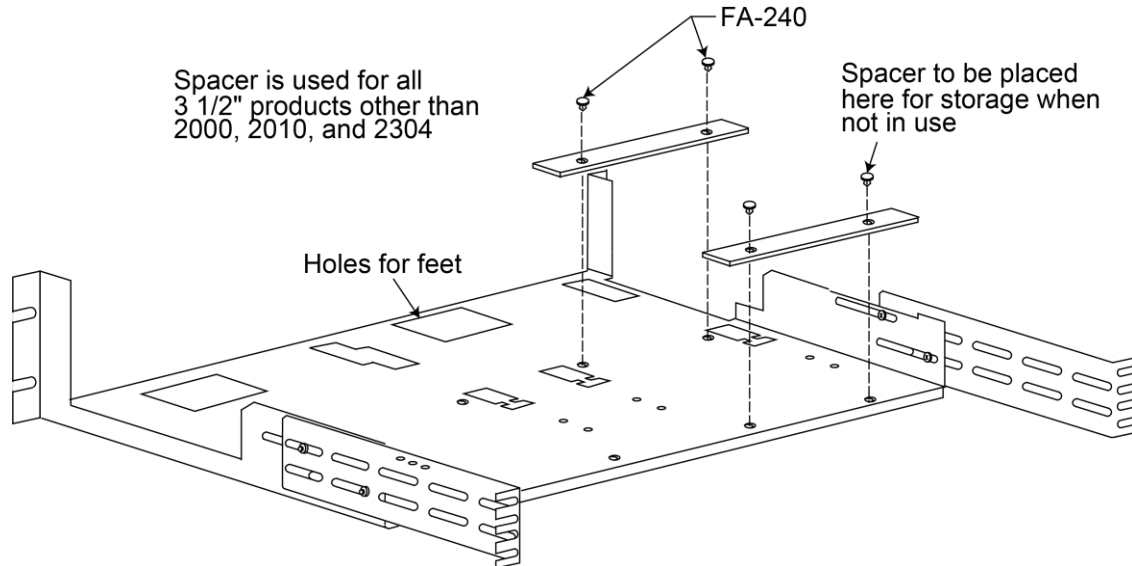

2. Slide the instruments onto the chassis shelf from the rear of the rack. The feet of each instrument will fit into holes in the shelf.
3. Attach the clamps to the chassis shelf with 8-32 x 3/8 in. screws. The clamps should extend over the lip on the rear panel of the instruments. Note that there are two sets of mounting holes for clamping 3½ in. high instruments of different lengths.
4. Tighten all screws.

The following safety precautions should be observed before using this product and any associated instrumentation. Although some instruments and accessories would normally be used with nonhazardous voltages, there are situations where hazardous conditions may be present.

This product is intended for use by qualified personnel who recognize shock hazards and are familiar with the safety precautions required to avoid possible injury. Read and follow all installation, operation, and maintenance information carefully before using the product. Refer to the user documentation for complete product specifications.

If the product is used in a manner not specified, the protection provided by the product warranty may be impaired.

The types of product users are:

Responsible body is the individual or group responsible for the use and maintenance of equipment, for ensuring that the equipment is operated within its specifications and operating limits, and for ensuring that operators are adequately trained.

Operators use the product for its intended function. They must be trained in electrical safety procedures and proper use of the instrument. They must be protected from electric shock and contact with hazardous live circuits.

Maintenance personnel perform routine procedures on the product to keep it operating properly, for example, setting the line voltage or replacing consumable materials. Maintenance procedures are described in the user documentation. The procedures explicitly state if the operator may perform them. Otherwise, they should be performed only by service personnel.

Service personnel are trained to work on live circuits, perform safe installations, and repair products. Only properly trained service personnel may perform installation and service procedures.

Keithley Instruments products are designed for use with electrical signals that are measurement, control, and data I/O connections, with low transient overvoltages, and must not be directly connected to mains voltage or to voltage sources with high transient overvoltages. Measurement Category II (as referenced in IEC 60664) connections require protection for high transient overvoltages often associated with local AC mains connections. Certain Keithley measuring instruments may be connected to mains. These instruments will be marked as category II or higher.

Unless explicitly allowed in the specifications, operating manual, and instrument labels, do not connect any instrument to mains.

Exercise extreme caution when a shock hazard is present. Lethal voltage may be present on cable connector jacks or test fixtures. The American National Standards Institute (ANSI) states that a shock hazard exists when voltage levels greater than 30 V RMS, 42.4 V peak, or 60 VDC are present. A good safety practice is to expect that hazardous voltage is present in any unknown circuit before measuring.

Operators of this product must be protected from electric shock at all times. The responsible body must ensure that operators are prevented access and/or insulated from every connection point. In some cases, connections must be exposed to potential human contact. Product operators in these circumstances must be trained to protect themselves from the risk of electric shock. If the circuit is capable of operating at or above 1000 V, no conductive part of the circuit may be exposed.

Do not connect switching cards directly to unlimited power circuits. They are intended to be used with impedance-limited sources. NEVER connect switching cards directly to AC mains. When connecting sources to switching cards, install protective devices to limit fault current and voltage to the card.

Before operating an instrument, ensure that the line cord is connected to a properly-grounded power receptacle. Inspect the connecting cables, test leads, and jumpers for possible wear, cracks, or breaks before each use.

When installing equipment where access to the main power cord is restricted, such as rack mounting, a separate main input power disconnect device must be provided in close proximity to the equipment and within easy reach of the operator.

For maximum safety, do not touch the product, test cables, or any other instruments while power is applied to the circuit under test. ALWAYS remove power from the entire test system and discharge any capacitors before: connecting or disconnecting cables or jumpers, installing or removing switching cards, or making internal changes, such as installing or removing jumpers.

Do not touch any object that could provide a current path to the common side of the circuit under test or power line (earth) ground. Always make measurements with dry hands while standing on a dry, insulated surface capable of withstanding the voltage being measured.

For safety, instruments and accessories must be used in accordance with the operating instructions. If the instruments or accessories are used in a manner not specified in the operating instructions, the protection provided by the equipment may be impaired.

Do not exceed the maximum signal levels of the instruments and accessories, as defined in the specifications and operating information, and as shown on the instrument or test fixture panels, or switching card.

When fuses are used in a product, replace with the same type and rating for continued protection against fire hazard.

Chassis connections must only be used as shield connections for measuring circuits, NOT as protective earth (safety ground) connections.

If you are using a test fixture, keep the lid closed while power is applied to the device under test. Safe operation requires the use of a lid interlock.

If a  screw is present, connect it to protective earth (safety ground) using the wire recommended in the user documentation.

The  symbol on an instrument means caution, risk of danger. The user must refer to the operating instructions located in the user documentation in all cases where the symbol is marked on the instrument.

The  symbol on an instrument means caution, risk of electric shock. Use standard safety precautions to avoid personal contact with these voltages.

The  symbol on an instrument shows that the surface may be hot. Avoid personal contact to prevent burns.

The  symbol indicates a connection terminal to the equipment frame.

If this  symbol is on a product, it indicates that mercury is present in the display lamp. Please note that the lamp must be properly disposed of according to federal, state, and local laws.

The **WARNING** heading in the user documentation explains dangers that might result in personal injury or death. Always read the associated information very carefully before performing the indicated procedure.

The **CAUTION** heading in the user documentation explains hazards that could damage the instrument. Such damage may invalidate the warranty.

Instrumentation and accessories shall not be connected to humans.

Before performing any maintenance, disconnect the line cord and all test cables.

To maintain protection from electric shock and fire, replacement components in mains circuits — including the power transformer, test leads, and input jacks — must be purchased from Keithley Instruments. Standard fuses with applicable national safety approvals may be used if the rating and type are the same. Other components that are not safety-related may be purchased from other suppliers as long as they are equivalent to the original component (note that selected parts should be purchased only through Keithley Instruments to maintain accuracy and functionality of the product). If you are unsure about the applicability of a replacement component, call a Keithley Instruments office for information.

To clean an instrument, use a damp cloth or mild, water-based cleaner. Clean the exterior of the instrument only. Do not apply cleaner directly to the instrument or allow liquids to enter or spill on the instrument. Products that consist of a circuit board with no case or chassis (e.g., a data acquisition board for installation into a computer) should never require cleaning if handled according to instructions. If the board becomes contaminated and operation is affected, the board should be returned to the factory for proper cleaning/servicing.

Safety precaution revision as of January 2013.